

Customer's Name 客户名称:
美卡得智能

File. No 文件编号:
Version 版本: A
Date 日期: 2021-12-24

深圳市科恩瑟尔电池有限公司
Shenzhen Coincell Battery CO., LTD.

Specification For Approval

Model 型号 : KE18650-1S1P-2500

Customer Model 客户型号: _____

Approval 批准	Checked 审核	Draft 制定
Simon Luo	Mars Zong	Sun J
Customer Approval 客户回签		

深圳市科恩瑟尔电池有限公司

地址: 中国广东省深圳市龙华区
大浪街道华荣路龙兴商业大厦 508

Kelly Shu
17620552786
Kelly.shu@coincell.cn

History of specification

规格书修订记录

Date 日期	Contents 内容	Remarks 备注

Contents 目录

1. Scope 适用范围.....	4
2. Battery group Specification 电池组参数.....	4
3. The main parts list 主要零部件清单.....	5
4. Battery Performance Criteria 电池性能检查及测试	5
4.1 Appearance 外观和结构	5
4.2 Measurement Apparatus 测试设备要求.....	5
4.3 standard Test Condition 标准的测试条件	5
4.4 Conventional performance 常规性能	6
4.5 Safety Test 安全试验	6
4.6 环境安全试验.....	8
备注：“n”代表串联个数.....	8
5. Storage and Others 贮存及其它事项.....	8
5.1 Long Time Storage 长期贮存.....	8
5.2 Others 其它事项	8
6. Cell Drawing(all unit in mm, not in scale)电芯图纸	9
7. Protection Circuit 保护电路.....	9
7.1 Circuit Diagram 电路原理图.....	9
7.2 PCM parameter PCM 参数(reference)	10
7.3 PCM BOM PCM 清单.....	11
7.4 PCM Layout PCM 布线图	11
7.5 焊盘说明 Pad description	12
8. Assembly Drawing 装配图纸(reference).....	13
9. Label Drawing 商标图纸	13
Appendix 附录.....	14
1 Charging 充电	14
1.1 Charging current 充电电流.....	14
1.2 Charging voltage 充电电压.....	14
1.3 Charging temperature 充电温度	14
1.4 Prohibition of reverse charging 禁止反向充电.....	15
2 Discharging 放电.....	15
2.1 Discharging current 放电电流.....	15
2.2 Discharging temperature 放电温度	15
2.3 Over-discharging 过放电	15
3. Protection Circuit Module 保护电路模块.....	15
4. Storage 贮存	15
5. Handling Instructions 电池的注意事项.....	16
6. Amendment of this Specification 产品规格书的修订.....	17

1. Scope 适用范围

The specification shall be applied to Li-ion battery pack of KE18650-1S1P-2500, which is manufactured by SHENZHEN COINCELL BATTERY CO., LTD.. The product is ROHS compliant. 本规格书适用于深圳市科恩瑟尔电池有限公司生产的 KE18650-1S1P-2500 锂离子可充电电池.产品满足 ROHS 要求。

2. Battery group Specification 电池组参数

NO	Items	Criteria	Remarks	
2.1	Nominal Capacity 标称容量	2500mAh	Discharge:0.2CmA cut-off voltage 0.2C 放电至截止电压	
	Minimum Capacity 最小容量	2400mAh		
2.2	Nominal Voltage 标称电压	3.60V		
2.4	Open Circuit Voltage 出厂电压	$\geq 3.50V$	With in 10 days from Factory 在出厂 10 天内	
2.6	Internal Impedance 内阻	$\leq 120m\Omega$	AC 1KHz after standard charge 标准充电后 AC 1KHz 测试	
2.7	Charge voltage 充电限制电压	4.20V	By standard charge method 标准充电方式	
2.8	Standard charge current 标准充电电流	0.5C current charge to 4.20V, then CV to 0.02C cutoff @ RT.		
	Charge Temperature and Method 充电温度及方法	Temperature	Charge Current	Voltage
		0°C-15°C	0.2C	4.20V~2.5V
		15°C-25°C	0.5C	4.20V~2.5V
25°C-45°C	1.0C	4.20V		
2.9	Max. continuous charge current 最大持续充电电流	1.0C	4.20V	
2.10	Standard discharge current 标准放电电流	0.2C	2.5V	
2.11	Max. continuous discharge current 最大持续放电电流	10A	2.5V	
2.12	Discharge cut-off voltage 放电截止电压	2.5V	By standard discharge method 标准放电方式	
2.13	Operating Temperature 工作温度	0~+45°C	Charging 充电	
		-20~+60°C	Discharging 放电	
2.14	Storage Temperature 贮存温度	-10°C~+45°C	Less than 1 month 小于一个月	
		-10°C~+35°C	Less than 6 months 小于六个月	
2.15	Weight 重量	约 48g		

3. The main parts list 主要零部件清单

序号 number	物料名称 Material name	型号/规格 type/specification	单位 Unit	数量 Quantity
1	电芯 Cell	18650HE4/LG	pcs	1
2	保护板 PCBA	KE18650-1S1P-2500 IC: S-8261DBB-M6T1U/SOT-23-6 MOS: PDC2604Z/DFN3*3	pcs	1
3	连接器	UL3239 AWG18 红黑/UL3239 AWG22 白	pcs	1

4. Battery Performance Criteria 电池性能检查及测试

4.1 Appearance 外观和结构

There shall be no such defect as scratch, bur and other mechanical scratch, and the connector should be no rust dirt. The structure and dimensions see attached drawing of the battery.

电池的表面应无明显的划痕毛刺及其其它机械划伤，外露的金属端子应无锈蚀污垢。结构尺寸见电池的外形尺寸图；

4.2 Measurement Apparatus 测试设备要求

(1) Dimension Measuring Instrument 尺寸测量设备

The dimension measurement shall be implemented by instruments with equal or more precision scale of 0.01mm.

测量尺寸的仪器的精度应不小于 0.01mm

(2) Voltmeter 电压表

Standard class specified in the national standard or more sensitive class having inner impedance not less than 10 KΩ/V.

国家标准或更灵敏等级,内阻不小于 10 KΩ/V.

(3) Ammeter 电流表

Standard class specified in the national standard or more sensitive class. Total external resistance including ammeter and wire is less than 0.01Ω.

国家标准或更灵敏等级，外部总内阻包括电流表和导线应小于 0.01Ω.

(4) Impedance Meter 内阻测试仪

Impedance shall be measured by a sinusoidal alternating current method (AC 1kHz LCR meter).

内阻测试仪测试方法为交流阻抗法(AC 1kHz LCR).

4.3 standard Test Condition 标准的测试条件

Test should be conducted with new batteries within one month after shipment from our factory and the cells shall not be cycled more than five times before the test. Unless otherwise defined, test and measurement shall be done under temperature of 20±5℃ and relative humidity of 45~85%.

测试电池必须是本公司出厂时间不超过一个月的新电池，且电池未进行过五次以上充放电循环。除非其它特殊要求，本产品规格书规定的测试的环境条件为：温度 20±5℃，相对湿度 45%~85%。

4.4 Conventional performance 常规性能

No	Items/项目	测试方法 Test method	判定标准 Decision criteria
1	Charge Performance 充电性能	The standard charge mode :under the temperature of $20 \pm 5^{\circ}\text{C}$,charge the battery with the current of 0.5C until the voltage reaches up to $4.2\text{V} \times n$,then charge with constant voltage until the charge current $\leq 0.02\text{C}$, then stop charging. 标准充电模式: 在 $20 \pm 5^{\circ}\text{C}$ 条件下, 电池用 0.5C 充电, 当电池电压达到 $4.2\text{V} \times n$ 时改为恒压充电, 直到充电电流小于或等于 0.02C 时停止充电。	Charging time is about 2.5 ~ 3.5 h. Charging time is about 2.5 ~ 3.5h.
2	$0.2\text{C}_5\text{A}$ capacity $0.2\text{C}_5\text{A}$ 容量	Standard charging is completed, standing 0.5h, suspended in the environmental temperature for $(23 \pm 2)^{\circ}\text{C}$ condition, with $0.2\text{C}_5\text{A}$ current constant exile electric to $2.5\text{V} \times n$. 标准充电完成后, 搁置 0.5h, 在环境温度为 $(23 \pm 2)^{\circ}\text{C}$ 条件下, 以 $0.2\text{C}_5\text{A}$ 电流恒流放电到 $2.5\text{V} \times n$ 。	$\geq 300\text{min}$
3	$1\text{C}_5\text{A}$ Discharge Capacity $1\text{C}_5\text{A}$ 放电容量	Fast charging is completed, standing 0.5h, suspended in the environmental temperature for $(23 \pm 2)^{\circ}\text{C}$ condition, with $1\text{C}_5\text{A}$ current constant exile electric to $2.5\text{V} \times n$. 快速充电完成后, 搁置 0.5h, 在环境温度为 $(23 \pm 2)^{\circ}\text{C}$ 条件下, 以 $1\text{C}_5\text{A}$ 电流恒流放电到 $2.5\text{V} \times n$ 。	$\geq 51\text{min}$
4	Cycle Performance 循环寿命	Test condition ($23 \pm 2^{\circ}\text{C}$) 测试条件 ($23 \pm 2^{\circ}\text{C}$): A cycle is defined as a Standard Charge, 10 minute-rest and Standard Discharge, 10 minute-rest. The cell is to be cycled for 300 times . 一个充放电循环被定义为: 电芯标准充电后, 静止 10min, 然后标准放电, 静止 10 分钟。按照此定义将电芯循环 300 次。	Discharge Capacity (300th cycle) 放电容量 $\geq 80\% \times \text{Cmin}$

4.5 Safety Test 安全试验

No	Items/项目	Testing method and determinant standard /测试方法和判定标准	判定标准 Decision criteria
----	----------	--	---------------------------

1	Overcharge Protection Characteristics 过充电保护性能	Standard charging is completed, set the constant current and voltage supplier with 2times of the nominal voltage and current, then load it to the battery for 7h. 电池充满电后, 用恒流恒压源持续给电池加载 7h, 恒流恒压源电压设定为 2 倍标称电压, 电流设定为 2C 的外接电流。	不起火, 不爆炸 No fire No explosion
2	Over-discharge Protection Characteristics 过放电保护性能	Under the temperature of $23\pm 2^{\circ}\text{C}$, after discharging the battery with 0.2C to final voltage, then connect the load with $(n*30)\Omega$ then discharge for 7h. 电池在环境温度为 $20^{\circ}\text{C}\pm 5^{\circ}\text{C}$ 的条件下, 以 0.2C ₅ A 放电至终止电压后, 外接 $(n*30\Omega)$ 负载放电 7h	不起火, 不爆炸 No fire No explosion
3	Short-circuit Protection Characteristics 短路保护性能	Rest for 30minutes at $(55\pm 2)^{\circ}\text{C}$ after Standard Charge, then short-circuit cells by connecting the positive and negative terminals with a circuit load having a resistance load(copper wire) of $80\pm 20\text{m}\Omega$. Test can be terminated when cell surface temperature has returned to $\pm 10^{\circ}\text{C}$ of environment temperature. 电池标准充电后, 将电池在 $(55\pm 2)^{\circ}\text{C}$ 的温度下恒温 30min, 然后用铜导线(总电阻 $80\pm 20\text{m}\Omega$)短接其正负极, 当电池表面温度恢复至高于环境温度 10°C 以内时, 结束实验。	不起火, 不爆炸 No fire No explosion
4	重物冲击 Heavy impact	Battery in the impact, 10 kg weight from 1 m high free fall, impact has been fixed in the battery in the jig 电池放置于冲击台上, 将 10Kg 重锤自 1m 高度自由落下, 冲击已固定在夹具中的电池。	不起火、不爆炸。 no fire, no explosion.
5	Hot impact 热冲击	Charging to 4.2V at constant current 1C5A, 以 1C5A, charging to the current $\leq 0.01\text{C}5\text{A}$ at constant voltage, lay aside 24h, put the battery in the hot-box, rise the tempt to $130^{\circ}\text{C}\pm 2^{\circ}\text{C}$ at the rate of $5^{\circ}\text{C}\pm 2)/\text{min}$, the battery should no fire, no explode. 恒流充电至电压 4.2V, 4.2V 恒压充电至电流 $\leq 0.01\text{C}5\text{A}$, 搁置 24h, 将电池放置于热箱中以 $(5^{\circ}\text{C}\pm 2)/\text{min}$ 的速率升至 $130^{\circ}\text{C}\pm 2^{\circ}\text{C}$ 并保温 30min, 电池应不起火, 不爆炸	不起火, 不爆炸 No fire No explosion

4.6 环境安全试验

6	恒定湿热性能 Constant humidity and temperature characteristics	<p>电池标准充电结束后，将电池放入（40±2）℃，相对湿度为 90%-95% 的恒温恒湿箱中搁置 48h 后，将电池取出在环境温度（23±2）℃ 的条件下搁置 2h，目测电池外观，再以 0.5C_{5A} 电流恒流放电至（n*2.5）V。Under the temperature of 23±2℃, after charging the battery with 0.2C, then put the battery into the constant temperature and humidity oven with 40±2℃ and 90~95% for 48h, the battery should be no obvious deformation, leakage, rust, smoking and explosion. After testing take out the battery then rest for 2h under the temperature of 23±2℃, discharge with 0.5C to (n*2.75)V.</p>	<p>放电时间≥36min 外观无变形、漏液、爆炸。 The discharge time is required ≥36min. Appearance no deformation ,no leakage, no explosion.</p>
7	Drop Test 跌落实验	<p>Under the temperature of 25±3℃, after full-charging the battery with 0.2C, then drop it freely from 1 meter height onto the hard board which concrete board(6 times each of X,Y,Z with positive and negative directions). 在 25±3℃ 条件下，电池按 0.2C 充满电后，将电池从 1 米高度自由跌落至混凝土板上（X、Y、Z 正负方向 6 个方向每个方向分别朝下跌落一次）</p>	<p>不漏液，不起火，不爆炸 No leakage. No fire No explosion 备注：不适应聚合物电池 Don't adapt to polymer battery</p>

备注：“n”代表串联个数

5. Storage and Others 贮存及其它事项

5.1 Long Time Storage 长期贮存

If stored for a long time(exceed three months), the cell should be stored in drying and cooling place. The cell's storage voltage should be (3.7~3.9V) *n and the cell is to be stored in a condition as appendix No. 4

长期贮存的电池（超过 3 个月）须置于干燥、凉爽处。贮存电压为(3.7~3.9V)*n 且贮存环境要求如附录.n 为串环节数

5.2 Others 其它事项

Any matters that this specification does not cover should be conferred between the customer and COINCELL. 任何本说明书中未提及的事项，须经双方协商确定。

6. Cell Drawing(all unit in mm, not in scale)电芯图纸

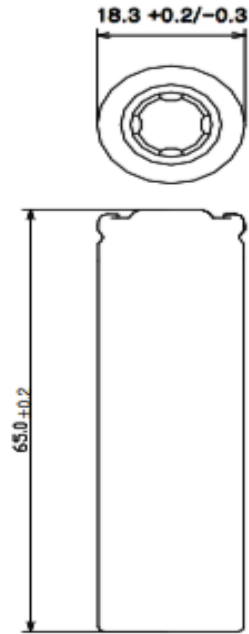

7. Protection Circuit 保护电路

7.1 Circuit Diagram 电路原理图

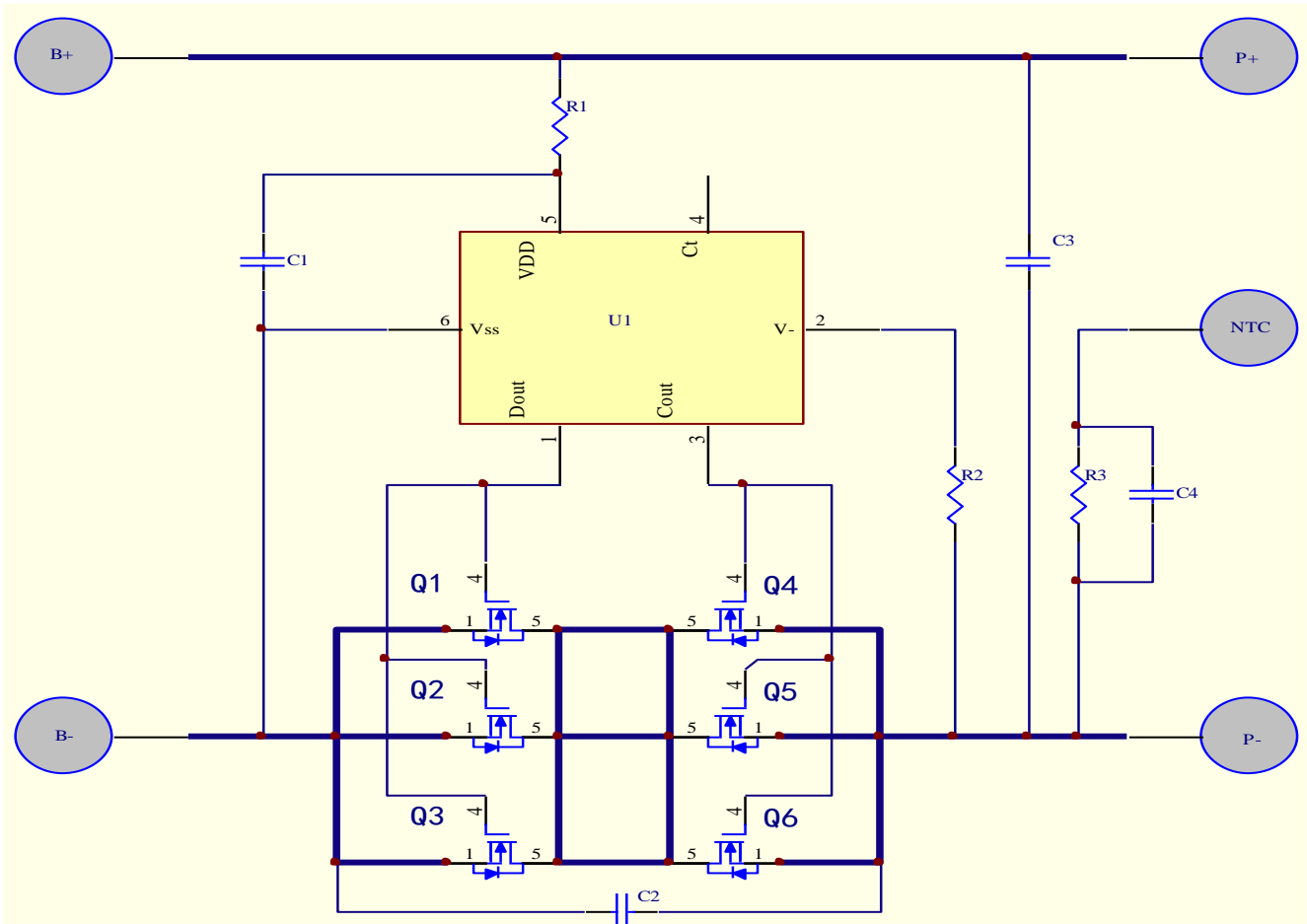

7.2 PCM parameter PCM 参数(reference)

保护 IC:	S-8261DBB-M6T1U	参数值 parameter value			
Protection IC:		温度-20℃~60℃ General temperature -20℃~60℃			
项目 item	最小值 Min.	典型值 Type value	最大值 Max.	单位 Unit	
过充保护电压 Over charge protection voltage	4.255	4.275	4.295	V	
过放保护电压 Over discharge protection voltage	2.225	2.300	2.350	V	
放电过流检测电压 Over current detection voltage	0.090	0.100	0.110	V	
充电过流检测电压 Over charge detection voltage	-0.0345	-0.0300	-0.0255	V	
放电过流保护电流 Over current protection current	23.00	40.00	57.00	A	
充电过流保护电流 charge over current protection current	20.00	20.00	60.00	A	
过充保护延迟时间 Over charge protection delay time	0.70	1.00	1.30	s	
过放保护延迟时间 Over discharge protection delay time	89.6	128	166.4	ms	
放电过流保护延迟时间 Over current protection delay time	5.6	8	10.4	ms	
短路保护延迟时间 Short protection delay time	190		364	us	
正常状态下静态电流 Current consumption (Operation)			6.0	uA	
过放状态下静态电流 Current consumption (Power down)	/	/	/	uA	
导通内阻 Impedance	PCM 内阻		40	mΩ	
输入电压 (B+与 B-间) Input voltage(B+ to B-)	-0.3		12	V	
最大持续充电电流 Max continuous charge current			10	A	
最大持续放电电流 Max continuous discharge current			20	A	
工作温度 Operating temperature	-20		+55	℃	
推荐存储条件 Recommendatory storage condition	Temperature range: -5~+35℃ Humidity: 0%~75%RH				
0V 电池充电功能 0V battery charge function	允许				

7.3 PCM BOM PCM 清单

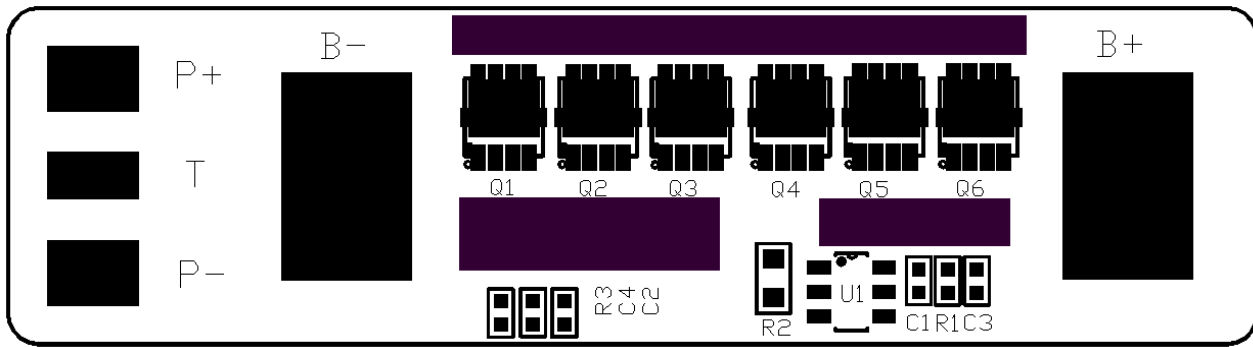

序号	物料名称	型号/规格	代号	品牌/HSF 要求	数量
1	PCB	48.0*13.0*1.0/FR-4/两层/喷锡/ 黑底白字		/ROHS	1
2	锂电保护 IC	S-8261DBB-M6T1U/SOT-23-6	U1	精工/ROHS	1
3	贴片 MOS	PDC2604Z/DFN3*3	Q1-Q6	博盛/ROHS	6
4	贴片电阻	0402, 330 Ω , $\pm 5\%$, 1/16W	R1	国巨/ROHS	1
5	贴片电阻	0402, 470K Ω , $\pm 5\%$, 1/16W	R2	国巨/ROHS	1
6	贴片 NTC	SNC473B14050F0402E 0402, 47K Ω , 1%, B=4050	R3	仙桥/ROHS	1
7	贴片电容	0402, 0.1 μ F, 16V, X5R	C1-C4	国巨/ROHS	4
8	镍片	8.0mm*5.0mm*0.3mm	B+/B-	万峰/ROHS	2

7.4 PCM Layout PCM 布线图

TopLayer

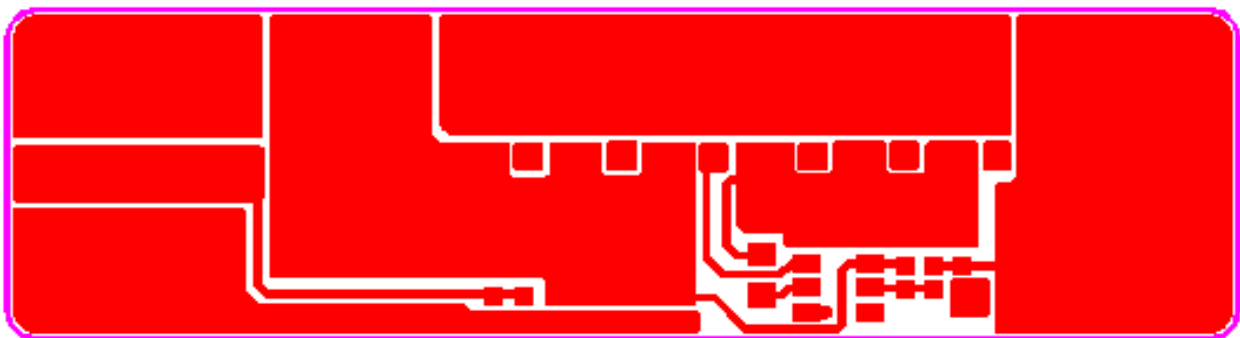

BottomLayer

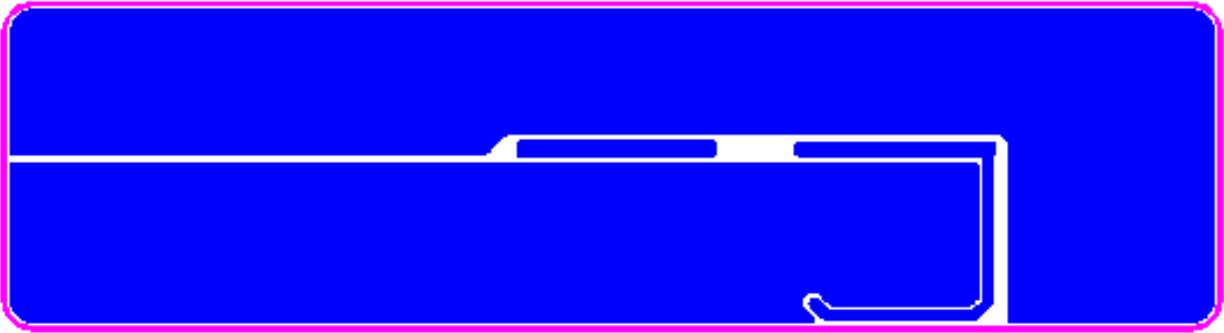

TopOverlay

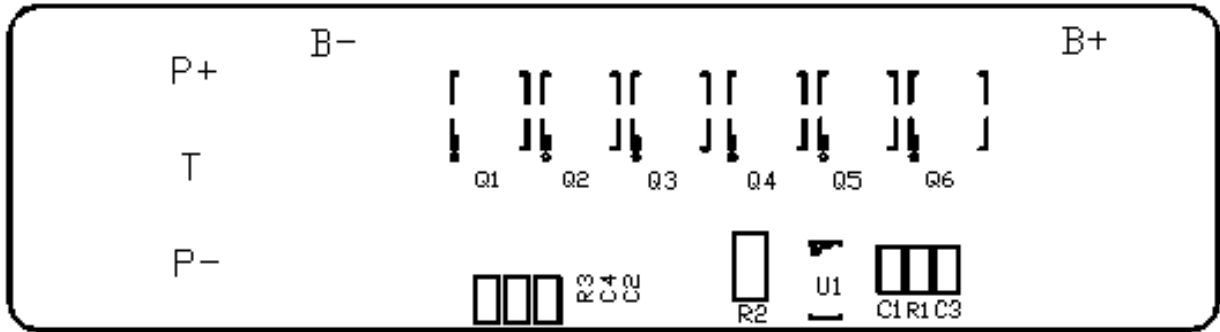

BottomOverlay

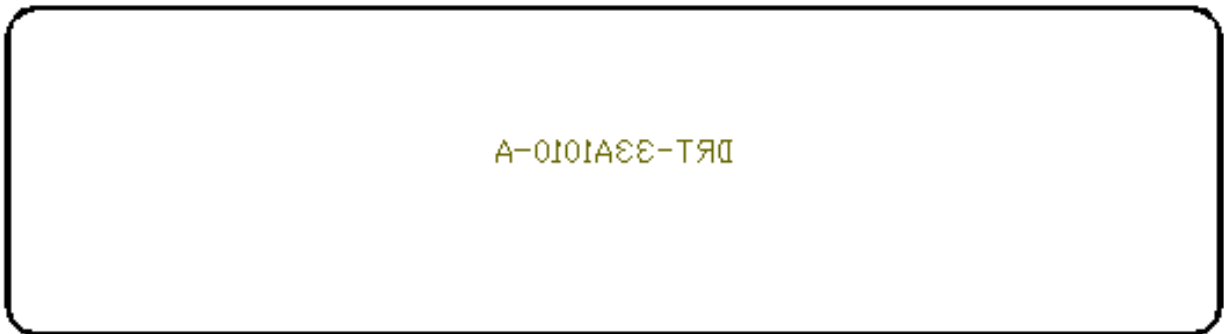

7.5 焊盘说明 Pad description

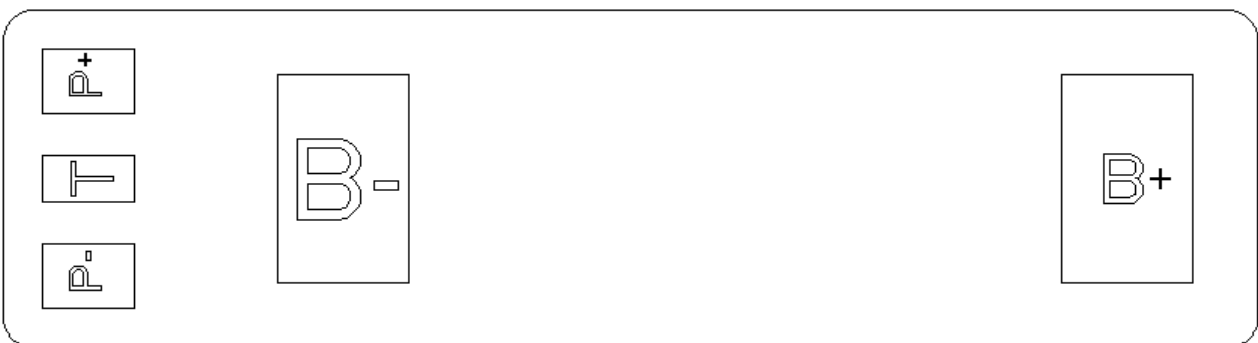

符号 Symbol	说 明 Description	符号 Symbol	说 明 Description
--------------	--------------------	--------------	--------------------

B+	接电芯正极 Cell Postive pole	P+	充电输入的正极/放电输出正极 charging in positive pole /discharge output Postive pole
B-	接电芯负极 Cell negatiove pole	P-	充电输入的负极/放电输出负极 charging negative pole/discharge output negative pole
		NTC	47K 热敏电阻

8. Assembly Drawing 装配图纸(reference)

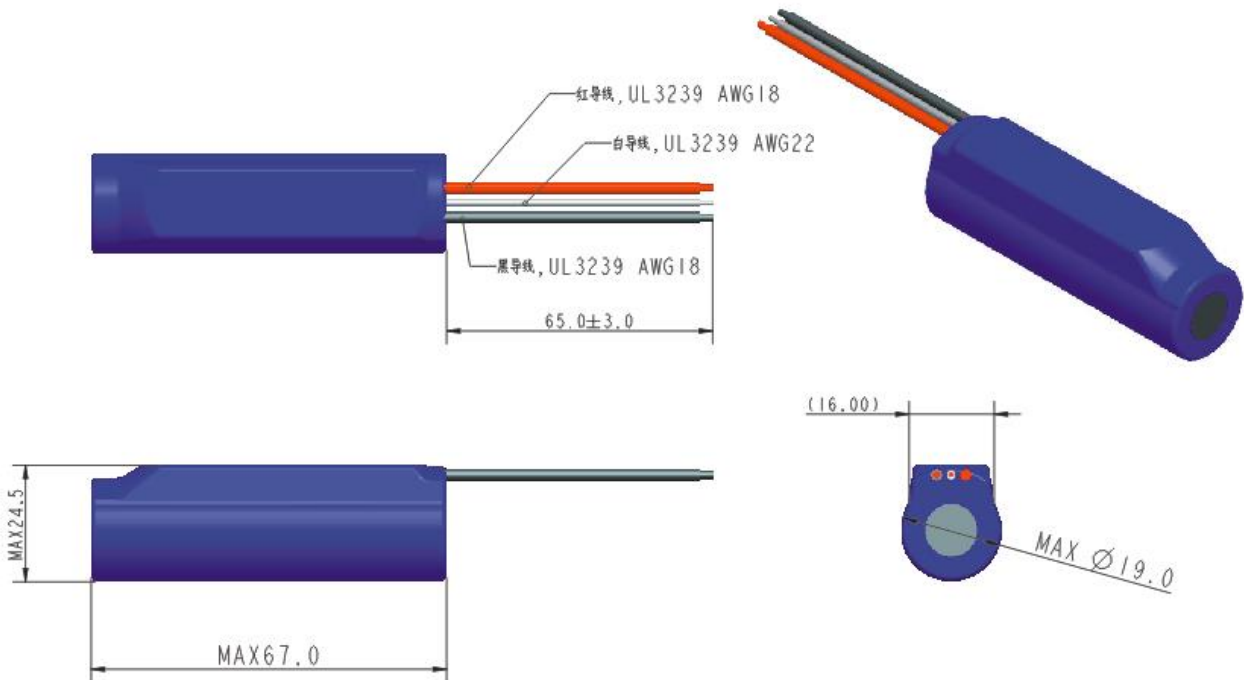

9. Label Drawing 商标图纸

Coincell KE18650-1S1P-2500 9Wh 3.6V 2500mAh YYMMDD
--

“YYMMDD” 随生产日期而变化

Appendix 附录

Handling Precautions and Guideline
For LIP (Lithium-Ion Polymer) Rechargeable Batteries
锂离子充电电池操作指示及注意事项

Preface 前言

This document of 'Handling Precautions and Guideline LIP Rechargeable Batteries' shall be

applied to the battery cells manufactured by **SHENZHEN COINCELL BATTERY CO., LTD.**

本档“锂离子充电电芯操作指示及注意事项”仅适用于深圳市科恩瑟尔电池有限公司生产电芯。

Note (1) : 声明一

The customer is requested to contact **SHENZHEN COINCELL BATTERY CO., LTD.**

in advance, if and when the customer needs other applications or operating conditions than those described in this document. Additional experimentation may be required to verify performance and safety under such conditions.

客户若需要将电芯用于超出本规格书规定以外的设备，或在本规格书规定以外的使用条件下使用电芯，应事先联系深圳市科恩瑟尔电池有限公司，因为需要进行特定的实验测试以核实电芯在该使用条件下的性能及安全性。

Note (2) : 声明二

SHENZHEN COINCELL BATTERY CO., LTD. will take no responsibility for any accident when the cell is used under other conditions than those described in this Document.

对于在超出本规格书规定以外的条件下使用电芯而造成的任何意外事故，深圳市科恩瑟尔电池有限公司概不负责。

Note (3): 声明三

SHENZHEN COINCELL BATTERY CO., LTD. will inform, in a written form, the customer of improvement(s) regarding proper use and handling of the cell, if it is deemed necessary.

如有必要，深圳市科恩瑟尔电池有限公司会以书面形式告知客户有关正确操作使用电芯的改进措施。

1 Charging 充电**1.1 Charging current 充电电流**

Charging current should be less than maximum charge current specified in the Product Specification. Charging with higher current than recommended value may cause damage to cell electrical, mechanical, and safety performance and could lead to heat generation or leakage.

充电电流不得超过本规格书中规定的最大充电电流。使用高于推荐值电流充电将可能引起电芯的充放电性能、机械性能和安全性能的问题，并可能会导致发热或泄漏。

1.2 Charging voltage 充电电压

It is very dangerous that charging with higher voltage than maximum voltage may cause damage to the cell electrical, mechanical safety performance and could lead to heat generation or leakage.

电池电压高于额定电压值时，将可能引起电芯的充放电性能、机械性能和安全性能的问题，可能会导致发热或泄漏。电池电压高于额定电压值时，将可能引起电芯的充放电性能、机械性能和安全性能的问题，可能会导致发热或泄漏。

1.3 Charging temperature 充电温度

The cell shall be charged within **0°C~45 °C** range in the Product Specification.

电池必须在 $0^{\circ}\text{C}\sim 45^{\circ}\text{C}$ 的环境温度范围内进行充电。

1.4 Prohibition of reverse charging 禁止反向充电

Reverse charging is prohibited. The cell shall be connected correctly. The polarity has to be confirmed before wiring. In case of the cell is connected improperly, the cell cannot be charged. Simultaneously, the reverse charging may cause damaging to the cell which may lead to degradation of cell performance and damage the cell safety, and could cause heat generation or leakage.

正确连接电池的正负极，严禁反向充电。若电池正负极接反，将无法对电芯进行充电。同时，反向充电会降低电芯的充放电性能、安全性，并会导致发热、泄漏。

2 Discharging 放电

2.1 Discharging current 放电电流

The cell shall be discharged at less than the maximum discharge current specified in the Product Specification. High discharging current may reduce the discharging capacity significantly or cause over-heat.

放电电流不得超过本规格书规定的最大放电电流，大电流放电会导致电芯容量剧减并导致过热。

2.2 Discharging temperature 放电温度

The cell shall be discharged within $-10^{\circ}\text{C}\sim 60^{\circ}\text{C}$ range specified in the Product Specification.

电池必须在 $-10^{\circ}\text{C}\sim 60^{\circ}\text{C}$ 的环境温度范围内进行放电。

2.3 Over-discharging 过放电

It should be noted that the cell would be at an over-discharged state by its self-discharge characteristics in case the cell is not used for long time. In order to prevent over-discharging, the cell shall be charged periodically. .

需要注意的是，在电池长期未使用期间，它可能会用其自放电特性而处于某种过放电状态。为防止过放电的发生，电池应定期充电。

Over-discharging may causes loss of cell performance, characteristics, or battery functions
过放电会导致电芯性能、电池功能的丧失。

3. Protection Circuit Module 保护电路模块

The cell/battery pack shall be with a PCM that can protect cell/battery pack properly. PCM shall have functions of (1) overcharging prevention, (2) over-discharging prevention, (3) over current prevention to maintain safety and Prevent significant deterioration of cell performance. The over current can occur by external short circuit

电芯/电池包装应配有 PCM 以正确保护电芯/电池。PCM 应具有以下功能以保证安全并防止损坏电池性能：(1) 过充保护功能；(2) 过放保护功能；(3) 过流保护

4. Storage 贮存

The cell shall be storied within $-10^{\circ}\text{C}\sim 45^{\circ}\text{C}$ range environmental condition.

电芯储存温度必须在 $-10^{\circ}\text{C}\sim 45^{\circ}\text{C}$ 的范围内。

If the cell has to be storied for a long time (Over 3 months), the environmental condition should be:

Temperature: $23\pm 5^{\circ}\text{C}$

Humidity: $65\pm 20\% \text{RH}$

长期存储电池（超过 3 个月）须置于温度为 $23\pm 5^{\circ}\text{C}$ 、湿度为 $65\pm 20\% \text{RH}$ 的环境中。

The voltage for a long time storage shall be $(3.7\text{V}\sim 3.9\text{V})\cdot n$ range.

贮存电压为 $(3.7\text{V}\sim 3.9\text{V})\cdot n$ 。n 为串联节数

5. Handling Instructions 电池的注意事项

Read and observe the following warnings and precautions to ensure correct and safe use of Li-ion batteries.

认真阅读下面的注意事项，确保正确使用锂离子电池。深圳市科恩瑟尔电池有限公司对违反下述注意事项而产生的任何问题不予负责。

Danger! 危 险!

- Do not immerse the battery in water or allow it to get wet.
- 勿将电池投入水中或将其弄湿!
- Do not use or store the battery near sources of heat such as a fire or heater.
- 禁止在火源或极热条件下给电池充电! 勿在热源(如火或加热器)附近使用或贮存电池! 如果电池泄漏或发出异味, 应立即将其从接近明火处移开;
- Do not use any chargers other than those recommended.
- 请使用专用充电器!
- Do not reverse the positive (+) and negative (-) terminals.
- 勿将正负极接反!
- Do not connect the battery directly to wall outlets or car cigarette-lighter sockets.
- 勿将电池直接连接到墙上插座或车载点烟式插座上!
- Do not put the battery into a fire or apply direct heat to it.
- 勿将电池投入火中或给电池加热!
- Do not short-circuit the battery by connecting wires or other metal objects to the positive (+) and negative (-) terminals.
- 禁止用导线或其它金属物体将电池正负极短路, 禁止将电池与项链、发夹或其它金属物体一起运输或贮存!
- Do not pierce the battery casing with a nail or other sharp object, break it open with a hammer, or step on it.
- 禁止用钉子或其它尖锐物体刺穿电池壳体, 禁止锤击或脚踏电池!
- Do not strike, throw or subject the battery to sever physical shock.
- 禁止撞击、投掷或者使电池受到机械震动
- Do not directly solder the battery terminals.
- 禁止直接焊接电池端子!
- Do not attempt to disassemble or modify the battery in any way.
- 禁止以任何方式分解电池!
- Do not place the battery in a microwave oven or pressurized container.
- 禁止将电池置入微波炉或压力容器中!
- Do not use the battery in combination with primary batteries (such as dry-cell batteries) or batteries of different capacity, type or brand.
- 禁止与一次电池(如干电池)或不同容量、型号、品种电池组合使用!
- Do not use the battery if it gives off an odor, generates heat, becomes discolored or deformed, or appears abnormal in any way. If the battery is in use or being recharged, remove it from the device or charger immediately and discontinue use.
- 如果电池发出异味、发热、变形、变色或出现其它任何异常现象时不得使用; 如果电池正在使用或充电, 应立即从用电器中或充电器上取出并停止使用!

Caution! 注 意!

Do not use or store the battery where is exposed to extremely hot, such as under window of a car in

direct sunlight in a hot day. Otherwise, the battery may be overheated. This can also reduce battery performance and/or shorten service life.

不要使用处于极热环境中的电池，如阳光直射或热天的车内。否则，电池会过热，可能着火（点燃），这样就会影响电池的性能、缩短电池的使用寿命。

If the battery leaks and electrolyte gets in your eyes, do not rub them. Instead, rinse them with clean running water and immediately seek medical attention. If left as is, electrolyte can cause eye injury.

如果电池漏液后电解液进入眼睛，不要擦，应用水冲洗，立即寻求医疗救助。如不及时处理，眼睛将会受到伤害。

Use the battery only under the following environmental conditions. Failure to do so can result in reduced performance or a shorten service life. Recharging the battery outside of these temperatures can cause the battery to overheat, explode or catch fire.

只能在下述条件下使用电池，否则将会降低电池的性能或缩短电池的使用寿命。

Operating environment:

工作环境

When charging the battery: 0°C~45°C

充电: 0°C~45°C

When discharging the battery: -20°C~60°C

放电: -20°C~60°C

When stored up to 30 days: -10°C~45°C

储存 30 天: -10°C~45°C

When stored up to 90 days: -10°C~35°C

储存 90 天: -10°C~35°C

6.Amendment of this Specification 产品规格书的修订

This specification is subject to change with prior notice.

本公司有权对本产品规格书进行修订，在对产品规格书修订后深圳市科恩瑟尔电池有限公司将会通知客户。